

# **REPLACEMENT LATCH SIDE Z-BAR INSTALLATION** **INSTRUCTIONS FOR SCREEN / WOOD CORE / ULTRACORE /** **MAXXVIEW / FFL / FSS / TRADITIONAL / CROSSBUCK DOORS**

IF YOU HAVE ANY QUESTIONS REGARDING THE INSTALLATION OF THE REPLACEMENT Z-BAR PLEASE CALL OUR CUSTOMER SERVICE DEPARTMENT AT 1-800-933-3626.

## **1. OPEN DOOR:**

Open the door and set the closers to keep the door open. This will aid in the removing of the Z-bar and the installing of the replacement Z-bar.

## **2. REMOVE SCREW COVER:**

Remove the screw cover from the latch side Z-bar by prying up the edge with a screwdriver and peeling the cover from the screw cover track.

NOTE: FFL and FSS doors do not have screw covers, skip to step 3 if you have one of these doors.

## **3. REMOVE Z-BAR:**

Remove the eight (8) screws from the Z-bar. The screws do not need to be saved. Screws are provided in the kit to install the replacement Z-bar.

NOTE: THE TRADITIONAL, CROSSBUCK, ULTRACORE, FFL, FSS AND MAXXVIEW DOOR Z-BARS ONLY HAVE SEVEN (7) SCREWS TO BE REMOVED INSTEAD OF EIGHT (8).

## **4. CUTTING THE REPLACEMENT Z-BAR:**

To cut the replacement Z-bar to length, measure down from the underside of the dripcap to the top of the door sill on the latch side of the door opening. Using this measurement, measure down from the top of the Z-bar and mark a line on the bottom of the Z-bar with a square and a pencil. Cut the Z-bar to length using a hacksaw.

NOTE: WHEN CUTTING THE SCREEN DOOR Z-BAR, IT IS POSSIBLE THAT THE BOTTOM MOUNTING HOLE WILL BE CUT OFF. THIS WILL NOT AFFECT THE FUNCTION OF THE DOOR.

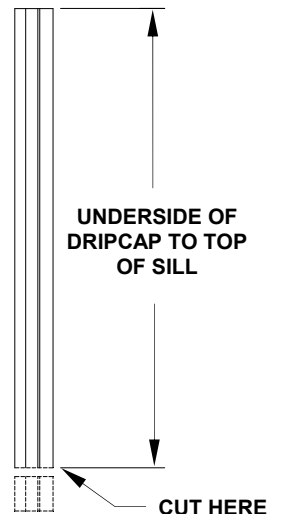

## **5. INSTALLING THE REPLACEMENT Z-BAR:**

NOTE: STEP 5 VARIES DEPENDING ON YOUR DOOR STYLE. FOLLOW THE INSTRUCTIONS FOR YOUR DOOR STYLE ONLY.

**5A. TRADITIONAL / CROSSBUCK DOORS ONLY:**

Position the Z-bar in the opening with the proper spacing using the temperature spacing chart below. THIS IS VERY IMPORTANT ! Hold the Z-bar in position with the proper spacing. (The holes in the Z-bar should be aligned with the holes in the brickmold. If not, drill 1/8" pilot holes.) Secure the Z-bar to the brickmold using seven (7) #8 x 1" screws. Remove the label from the Z-bar.

IMPORTANT: ALLOW PROPER SPACING BETWEEN THE EDGE OF THE DOOR AND THE REPLACEMENT Z-BAR FOR CONTRACTION AND EXPANSION, USING THE FOLLOWING TEMPERATURE GUIDELINES.

OUTSIDE TEMPERATURE AT TIME OF INSTALLATION	SPACE ALLOWANCE (X)
UNDER 30° F	1/2"
30° TO 49°	7/16"
50° TO 69°	3/8"
OVER 70° F	5/16"

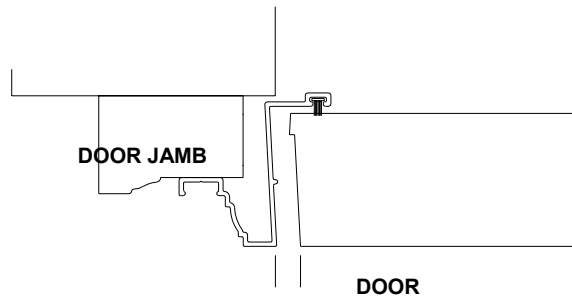

**5B. INSTALLING REPLACEMENT Z-BAR: (WOOD CORE ONLY)**

Position the Z-bar so that the holes line up with the holes already in the brickmold. In this position, there should be approximately a 3/16" gap between the door edge and the Z-bar. Secure the Z-bar to the brickmold using eight (8) #8 x 1" screws.

NOTE: IF THE HOLES IN THE Z-BAR DO NOT LINE UP WITH THE HOLES IN THE BRICKMOLD, DRILL 1/8" PILOT HOLES BEFORE INSTALLING THE SCREWS.

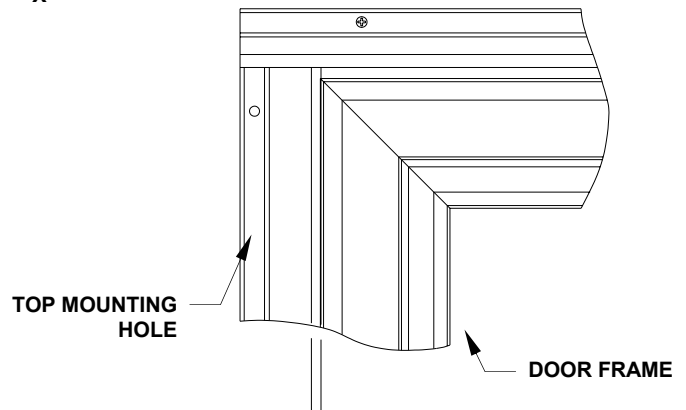

**5C. INSTALLING REPLACEMENT Z-BAR: (SCREEN DOOR ONLY)**



Position the Z-bar so that the holes line up with the holes already in the brickmold. In this position, there should be approximately a 1/4" gap between the door edge and the Z-bar. Secure the Z-bar to the brickmold using eight (8) #8 x 1" screws. \*

\* IF THE BOTTOM MOUNTING HOLE WAS CUT OFF IN STEP 4, THE INSTALLATION WILL ONLY REQUIRE SEVEN (7) SCREWS.

NOTE: IF THE HOLES IN THE Z-BAR DO NOT LINE UP WITH THE HOLES IN THE BRICKMOLD, DRILL 1/8" PILOT HOLES BEFORE INSTALLING THE SCREWS.

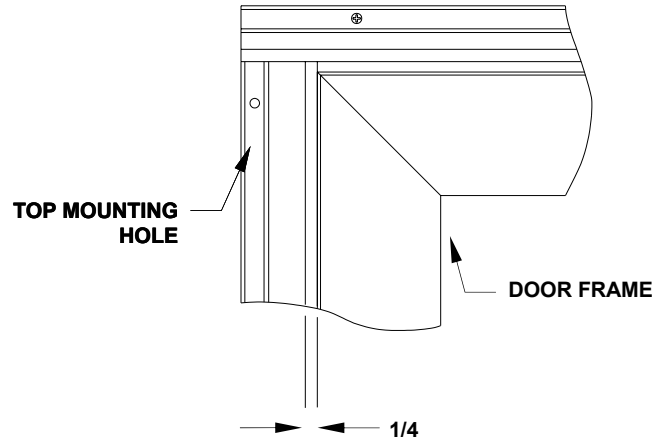

**5D. INSTALLING REPLACEMENT Z-BAR: (MAXXVIEW, FFL, FSS ONLY)**

Position the Z-bar so that the holes line up with the holes already in the brickmold. In this position, there should be approximately a 1/4" gap between the door edge and the Z-bar. Secure the Z-bar to the brickmold using seven (7) #8 x 1" screws.

NOTE: IF THE HOLES IN THE Z-BAR DO NOT LINE UP WITH THE HOLES IN THE BRICKMOLD, DRILL 1/8" PILOT HOLES BEFORE INSTALLING THE SCREWS.

If you are replacing the Z-bar for an FFL or FSS door, your installation is now complete. The area between the Z-bar and jamb can be caulked if desired.

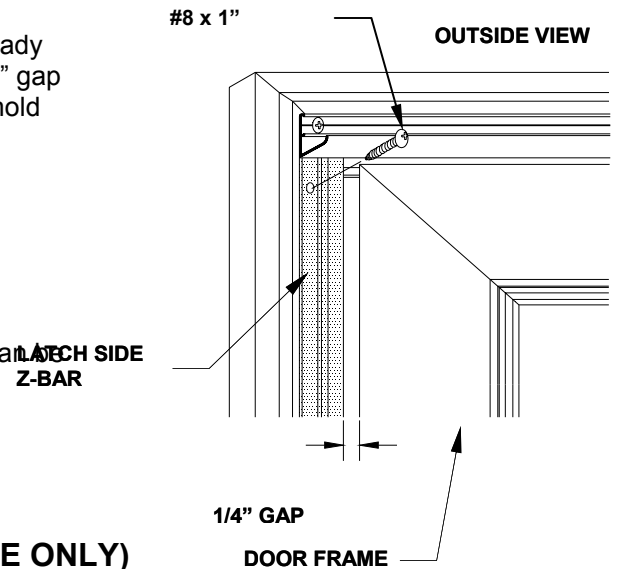

**5E. INSTALLING REPLACEMENT Z-BAR: (ULTRACORE ONLY)**

Position the Z-bar so that the holes line up with the holes already in the brickmold. In this position, there should be approximately a 3/16" gap between the door edge and the Z-bar. Secure the Z-bar to the brickmold using seven (7) #8 x 1" screws.

NOTE: IF THE HOLES IN THE Z-BAR DO NOT LINE UP WITH THE HOLES IN THE BRICKMOLD, DRILL 1/8" PILOT HOLES BEFORE INSTALLING THE SCREWS.

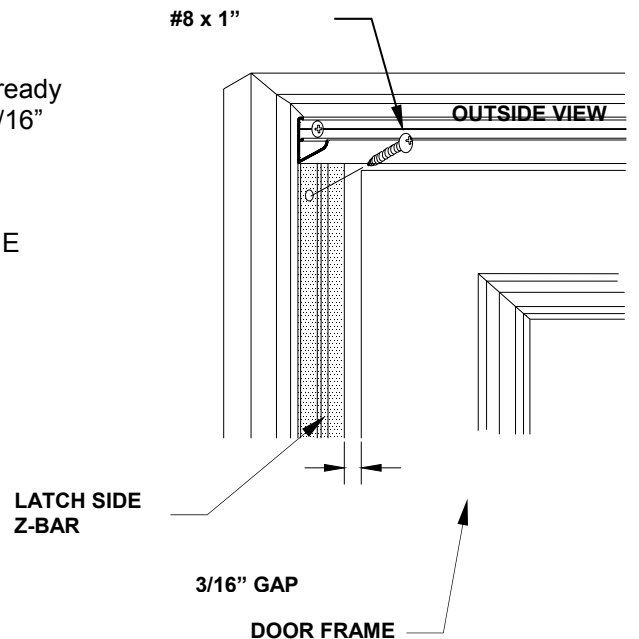

## **6. INSTALLING SCREW COVER:**

Place the edge of the screw cover over the track at the top of the Z-bar. Using your thumb, press the screw cover into the track along the entire length of the Z-bar. Making sure that the screw cover is flush with the top of the Z-bar, trim off any excess at the bottom of the Z-bar with a razor knife or sharp scissors. If desired, the area between the Z-bar and the jamb can be caulked.

NOTE: TRADITIONAL / CROSSBUCK DOOR SCREW COVER INSTALLATION SHOWN.

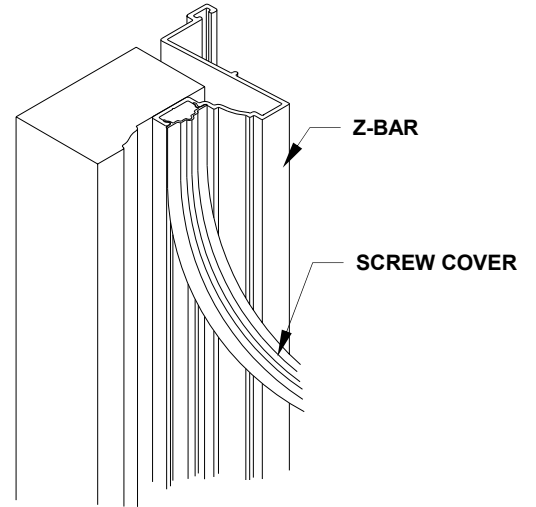

**EMCO SPECIALTIES, INC.**

P.O. Box 853  
Des Moines, Iowa 50304  
1-800-933-3626